

KBL12550 12V 55Ah



The KAISE LONG LIFE Series 10 years has been designed for different applications, such as UPS, electric and telecommunications applications that require a long useful life.

Performance Characteristics

Nominal Voltage	12V	
Dimensions	Length (mm / inch)	224 / 8.82
	Width (mm / inch)	132 / 5.20
	Height (mm / inch)	205 / 8.07
	Total Height (mm / inch)	210 / 8.27
Approx. Weight	(Kg / lbs) 17.3 / 38.2	
Design Life	10 years	
Terminal	M6	
Container Material	ABS	
Rated Capacity	56.5Ah / 5.65A	(10hr, 1.70V / cell, 25°C / 77°F)
	47.0Ah / 9.40A	(5hr, 1.70V / cell, 25°C / 77°F)
	33.3Ah / 33.3A	(1hr, 1.70V / cell, 25°C / 77°F)
Max. Discharge Current	550A (5s)	
Internal Resistance	Approx 7.2mΩ	
Operating Temp. Range	Discharge : -20 ~ 60°C (-4 ~ 140°F)	
	Charge : -10 ~ 60°C (14 ~ 140°F)	
	Storage : -20 ~ 60°C (-4 ~ 140°F)	
Nominal Operating Temp. Range	25 ± 3°C (77 ± 5°F)	
Cycle Use	Initial Charging Current less than 11A.	
	Voltage: 2.35VPC ~ 2.40VPC at 25°C (77°F)	
	Temp. Coefficient: -30mV/°C	
Standby Use	Initial Charging Current less than 11A.	
	2.25VPC ~ 2.30VPC at 25°C (77°F)	
	Temp. Coefficient: -20mV/°C	
Capacity affected by Temperature	40°C (104°F)	103%
	25°C (77°F)	100%
	0°C (32°F)	86%
Self Discharge	Fully charged Kaise Long Life Series batteries may be stored for up to 6 months at 25°C (77°F) and then a freshening charge is required. For higher temperatures the time interval will be shorter.	

Constant Current Discharge (Amperes) at 77°F (25°C)

Volts/cell	10min	15min	30min	1h	3h	5h	10h	20h
1.80V	99.8	79.5	51.9	31.7	13.3	9.06	5.50	2.88
1.75V	106	85.8	53.8	32.5	13.6	9.23	5.60	2.90
1.70V	115	90.6	55.6	33.3	13.9	9.40	5.65	2.92
1.65V	124	95.4	57.4	34.2	14.2	9.57	5.70	2.93
1.60V	129	99.4	59.2	35.1	14.6	9.82	5.75	2.94

Dimensions and Terminal (Unit: mm (inches))

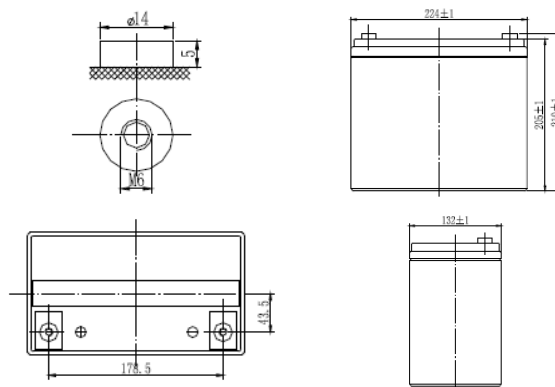

Applications

- UPS
- Telecommunications equipment
- Solar energy systems
- Cable TV
- Power station
- Marine equipment
- Military equipment
- Emergency power systems
- Railway systems

Certifications

ISO 9001:2008 ISO 14001:2008



Discharge Current vs. Discharge Voltage

Final discharge voltage V/CELL	1.8	1.75	1.7	1.6
Discharge current (A)	I ≤ 0.1CA	0.25CA ≥ I > 0.1CA	0.55CA ≥ I > 0.25CA	I > 0.55CA

Constant Power Discharge (Watts per cell) at 77°F (25°C)

Volts/cell	10min	15min	30min	45min	1h	2h	3h	5h
1.80V	186	154	104	78.4	62.6	37.4	26.7	17.9
1.75V	200	162	105	80.5	64.3	38.4	27.3	18.0
1.70V	213	169	107	82.3	65.8	39.4	27.9	18.2
1.65V	225	177	109	84.0	67.3	40.2	28.5	18.6
1.60V	238	185	111	85.3	68.9	41.1	29.1	18.8

(Note) The above characteristics data are average values obtained within three charge/discharge cycles not the minimum values.

Charging Characteristics (float use)

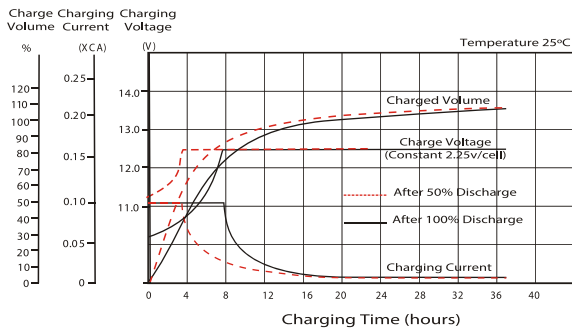

Cycle Life in Relation to Depth of Discharge

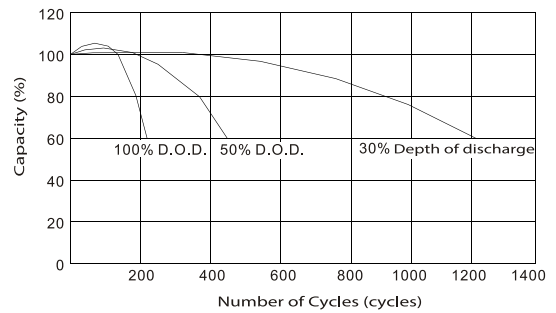

Temperature Effects in Relation to Battery Capacity

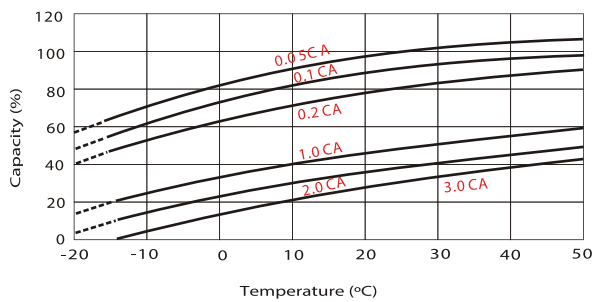

Effect of Temperature on Long Term Float Life

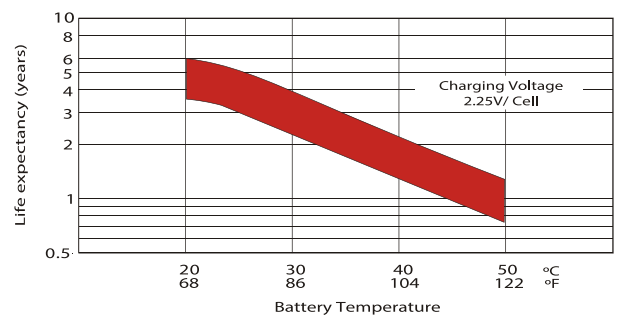

Self Discharge Characteristics

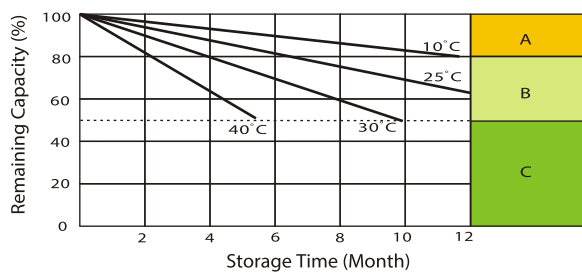

- A** No supplementary charge required
(carry out supplementary charge before use if 100% capacity is required)
- B** Supplementary charge required before use. Optional charging way as below:
 1. Charged for above 3 days at limited current 0.25 CA and constant voltage 2.25V / cell.
 2. Charged for above 20 hours limited current 0.25CA and constant voltage 2.45V / cell.
 3. Charged for 8-10 hours at limited current 0.05 CA.
- C** Supplementary charge often fail to recover the capacity.
The battery should never be left standing till this is reached.

IMPORTANT NOTE: The specifications presented herein are subject to revision without notice.

